

30-60-90 Right Triangles and Algebra Examples

1. **Lesson Review** – Name all the sides and angles in the following triangle.

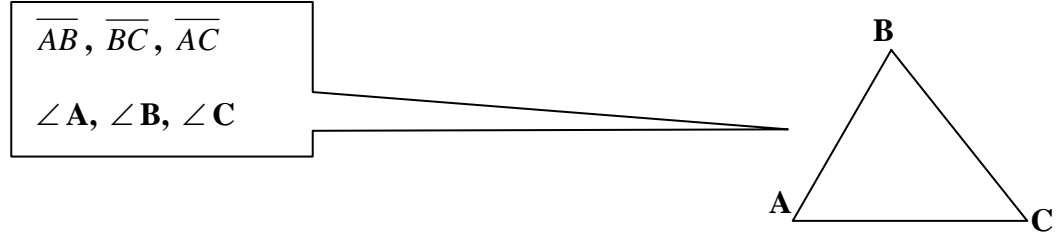

2. Suppose the measure of one **acute** angle of a right triangle is 30° . The measure of the other acute angle is $(90 - 30)^\circ$ or 60° . Such triangles are called **30° – 60° right triangles**.

An acute angle has a measure less than 90° .

3. Examine the equilateral triangle shown at the right. What is the measure of $\angle B$?

Since equilateral triangles have 3 equal angles then $180 \div 3 = 60$.

$$\angle B = 60^\circ$$

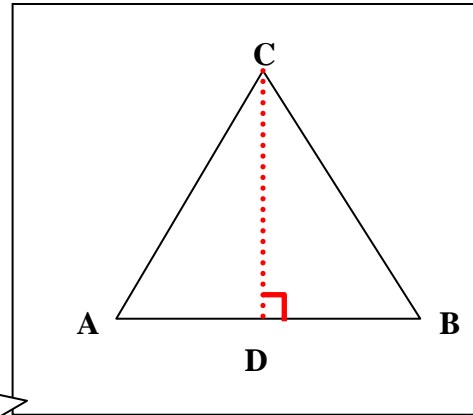

4. Line segment \overline{CD} (denoted \overline{CD}) can be drawn perpendicular to \overline{AB} . What kind of right triangle is triangle $\triangle CDB$ (denoted by $\triangle CDB$)?

$\angle C$ is cut in half. Therefore it is now 30° .

$\triangle CDB$ is a 30° – 60° – 90° triangle.

The hypotenuse of a right triangle is the side opposite the right angle.

5. **Thought Provoker** – \overline{CD} bisects \overline{AB} . Since the measure of \overline{DB} is one-half the measure of \overline{AB} , it is also one-half the measure of the hypotenuse, \overline{BC} . Why?

\overline{AB} and \overline{BC} have equal measures since $\triangle ABC$ is equilateral.

Make sure students understand that bisect means to cut into two equal parts.

6. In a $30^\circ-60^\circ-90^\circ$ triangle, the measure of the side opposite the 30° angle is one-half the measure of the hypotenuse.

This can also be stated as: In a $30^\circ-60^\circ-90^\circ$ triangle, the measure of the hypotenuse is twice the measure of the side opposite the 30° angle.

7. In calculations, lower-case letters are used to designate the measures of the sides of a triangle. For example, the measure of the side opposite angle R is side r; the measure of the side opposite angle X is x; and the measure of the side opposite angle Y is y.

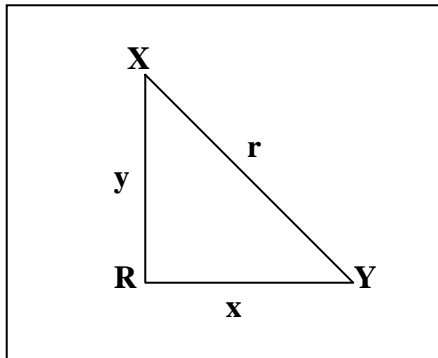

8. **Example** – Find the length of \overline{BC} in $\triangle ABC$. (See diagram on right)

$$a = \frac{1}{2}c$$

$$a = \frac{1}{2}(8)$$

$$a = 4$$

Thus, \overline{BC} is 4 units long.

The measure of the hypotenuse is c.

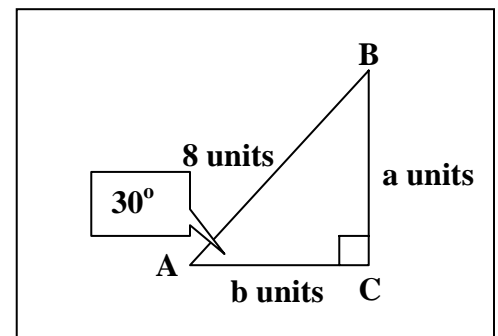

9. **EXAMPLE** – Find the length of \overline{BC} in $\triangle ABC$.

$$a = \frac{1}{2}c \Rightarrow \frac{1}{2}(5) \Rightarrow a = 2\frac{1}{2} \text{ units}$$

Thus, \overline{BC} is $2\frac{1}{2}$ units long.

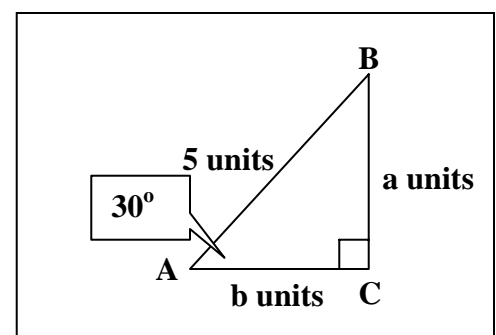

10. **EXAMPLE** – Find the length of \overline{PQ} in $\triangle PQR$.

$$r = 2q$$

$$r = 2(6)$$

$$r = 12$$

Thus, \overline{PQ} is 12 units long.

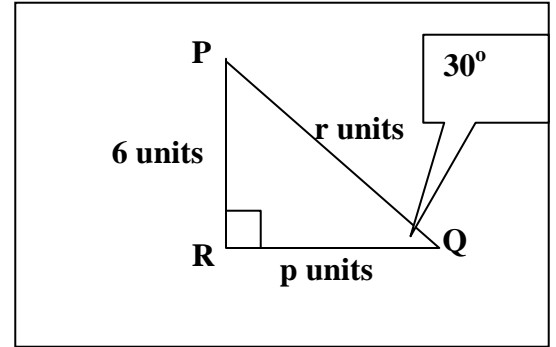

11. **Example** – Find the length of \overline{PQ} in $\triangle PQR$.

$$r = 2q$$

$$r = 2(3)$$

$$r = 6$$

Thus, \overline{PQ} is 6 units long.

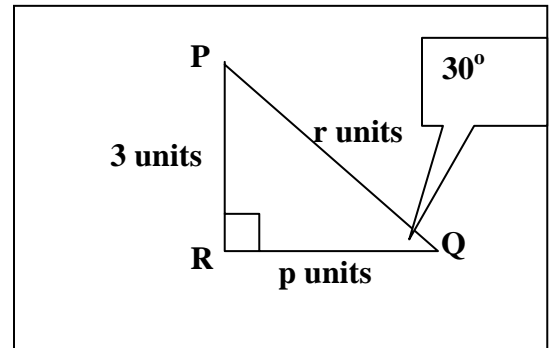

12. **Example** – Find the length of \overline{PQ} in $\triangle PQR$.

$$r = 2q$$

$$r = 2(5)$$

$$r = 10$$

Thus, \overline{PQ} is 10 units long.

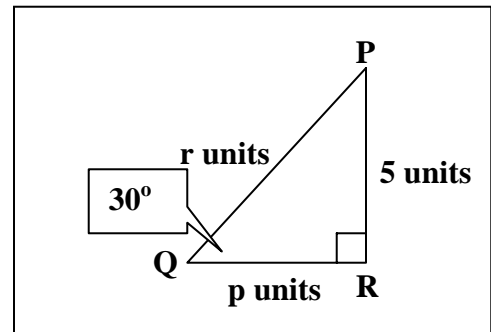

13. **Thought Provoker** – Suppose “a” represents the measure of the side opposite the 30° angle. How can you find the length of the side opposite the 60° angle in a 30° — 60° — 90° triangle?

$$a^2 + b^2 = c^2$$

Pythagorean Theorem

$$a^2 + b^2 = (2a)^2$$

$$a^2 + b^2 = 4a^2$$

$$b^2 = 4a^2 - a^2$$

$$b^2 = 3a^2$$

$$b = a\sqrt{3}$$

The measure of the hypotenuse is twice the measure of the side opposite the 30° angle.

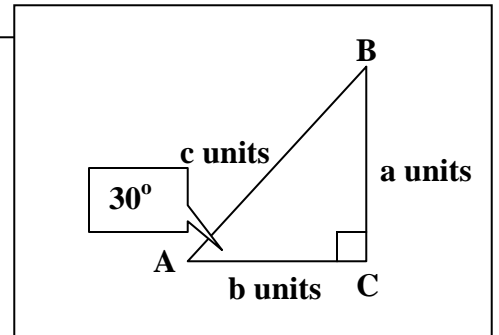

14. **Example** – Find the length of \overline{AC} in $\triangle ABC$.

$$b = a\sqrt{3}$$

$$b = 5\sqrt{3}$$

$$b \cong 5(1.732)$$

$$b \cong 8.660$$

Thus, \overline{AC} is approximately 8.660 units long.

The measure of the side opposite the 30° angle is a.

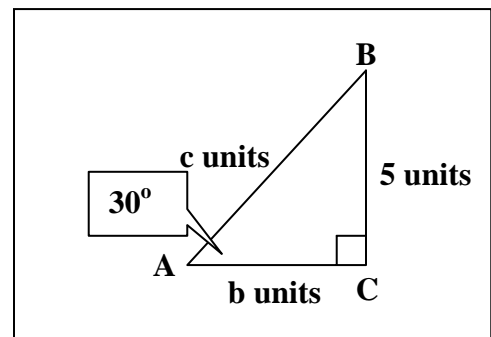

15. **Example** – Find the lengths of \overline{XY} and \overline{XZ} in $\triangle XYZ$.

$$x = z\sqrt{3}$$

$$8\sqrt{3} = z\sqrt{3}$$

$$8 = z$$

Divide each side by $\sqrt{3}$.

Since $y = 2z$, then $y = 2(8)$, or 16.

Thus, \overline{XY} is 8 units long and \overline{XZ} is 16 units long.

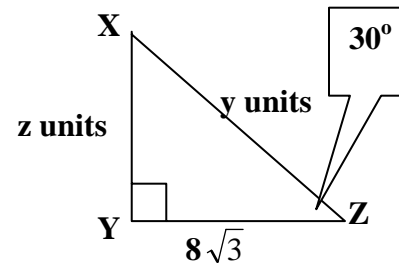

16. **Example** – Find the length of \overline{AC} in $\triangle ABC$.

$$b = a\sqrt{3}$$

$$b = 9\sqrt{3}$$

$$b \cong 9(1.732)$$

$$b \cong 15.588$$

Thus, \overline{AC} is approximately 15.588 units long.

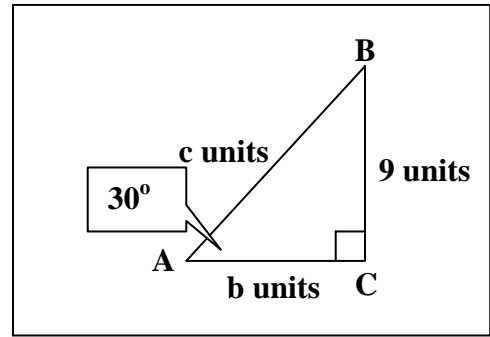

17. **Example** – Find the length of \overline{AC} in $\triangle ABC$.

$$b = a\sqrt{3}$$

$$b = 6\sqrt{3}$$

$$b \cong 6(1.732)$$

$$b \cong 10.392$$

Thus, \overline{AC} is approximately 10.392 units long.

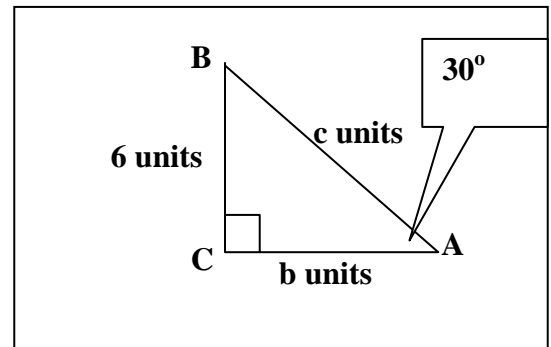

18. **Example** – Find the length of \overline{XY} and \overline{XZ} in $\triangle XYZ$.

$$x = z\sqrt{3}$$

$$4\sqrt{3} = z\sqrt{3}$$

$$4 = z$$

Since $y = 2z$, then $y = 2(4)$, or 8.

Thus, \overline{XY} is 4 units long and \overline{XZ} is 8 units long.

Divide both sides by $\sqrt{3}$.

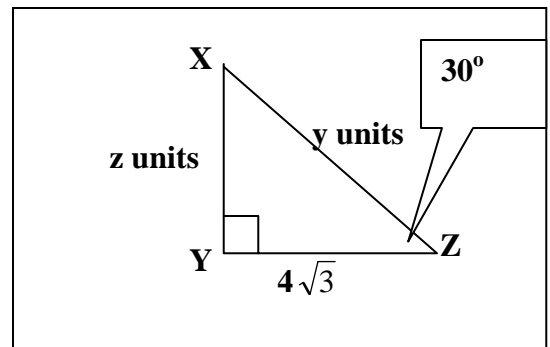

19. **Example** – Find the length of \overline{XY} and \overline{XZ} in $\triangle XYZ$.

$$x = z\sqrt{3}$$

$$3\sqrt{3} = z\sqrt{3}$$

$$3 = z$$

Since $y = 2z$, then $y = 2(3)$, or 6.

Thus, \overline{XY} is 3 units long and \overline{XZ} is 6 units long.

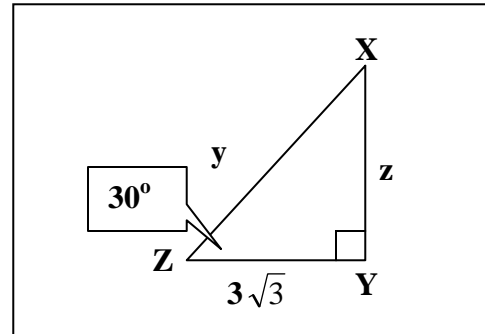

Name: _____

Date: _____

Class: _____

30-60-90 Right Triangles and Algebra Worksheet

The length of the hypotenuse of a 30° — 60° — 90° triangle is given. Find the length of the side opposite the 30° angle in each triangle.

1. 8 m

2. 16 cm

3. 13 mm

4. 9 mi

5. $4\frac{1}{2}$ in.

6. $3\frac{3}{8}$ in.

7. 16.36 m

8. 4.63 cm

The length of the side opposite the 30° angle in a 30° — 60° — 90° triangle is given. Find the length of the hypotenuse in each triangle.

9. 7 m

10. 6.2 cm

11. 4.35 mm

12. $4\frac{1}{2}$ mi

13. $6\frac{3}{8}$ in.

14. 13 m

15. 3.86 cm

16. $7\frac{3}{4}$ in

The length of the side opposite the 60° angle in 30° — 60° — 90° triangle is given. Find the length of the other two sides in each triangle.

17. $4\sqrt{3}$ ft

18. $2\sqrt{3}$ cm

19. $8\sqrt{3}$ m

20. $\sqrt{3}$ mi

21. $7\sqrt{3}$ yd

22. $9\sqrt{3}$ mm

Find the length of the third side in each triangle. Irrational answers are to be given in simplest form and then use a calculator to find answers to the nearest thousandths.

23.

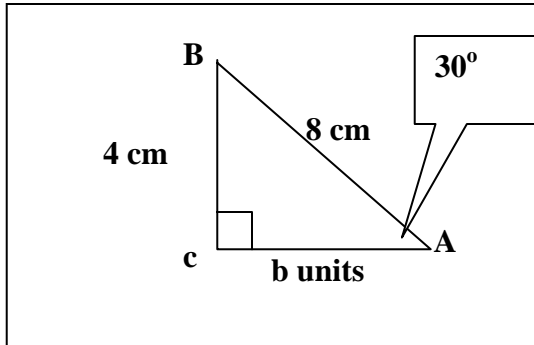

24.

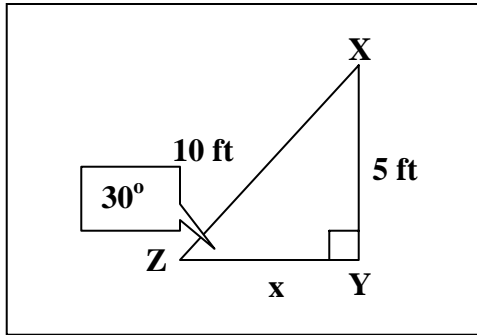

25.

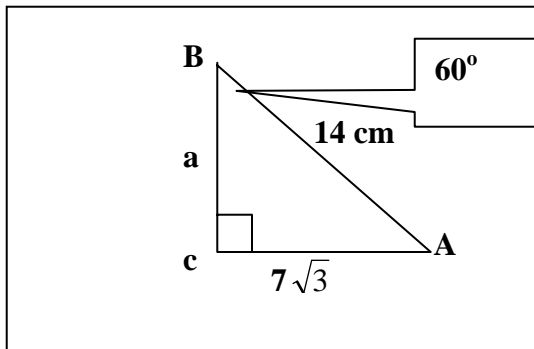

26.

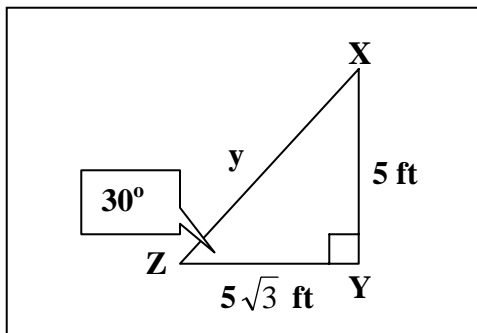

27.

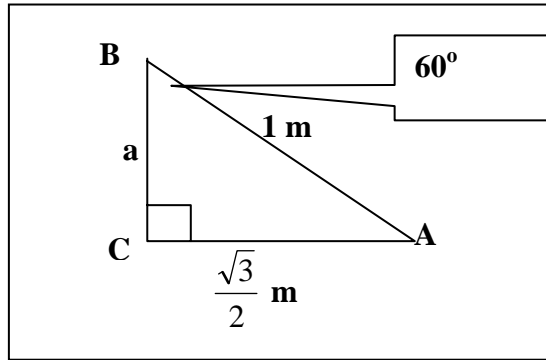

28.

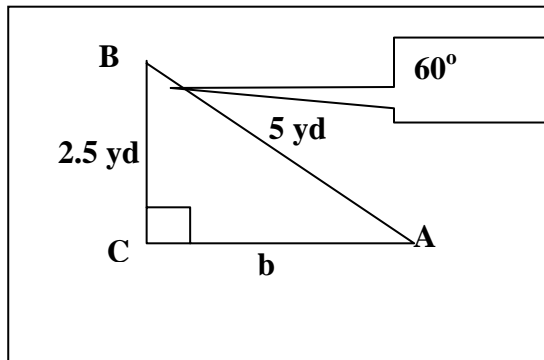

Find the lengths of the missing sides of each 30° — 60° — 90° triangle described below. Irrational answers are to be given in simplest form and then use a calculator to find answers to the nearest thousandths.

Question	Hypotenuse	Side Opposite 30° Angle	Side Opposite 60° Angle
29	6 m		
30	4.75 mm		
31	$3\frac{1}{2}$ in.		
32		8 cm	
33		6.5 m	
34		$3\frac{1}{4}$ in.	
35			$\sqrt{12}$
36			$3.5\sqrt{3}$

30-60-90 Right Triangles and Algebra Worksheet Key

The length of the hypotenuse of a 30° — 60° — 90° triangle is given. Find the length of the side opposite the 30° angle in each triangle.

1. $8 \text{ m} \rightarrow \frac{1}{2}(8) = 4 \text{ m}$

5. $4\frac{1}{2} \text{ in.} \rightarrow \frac{1}{2}(4\frac{1}{2}) = 2\frac{1}{4} \text{ in.}$

2. $16 \text{ cm} \rightarrow \frac{1}{2}(16) = 8 \text{ cm}$

6. $3\frac{3}{8} \text{ in.} \rightarrow \frac{1}{2}(3\frac{3}{8}) = 1\frac{11}{16} \text{ in.}$

3. $13 \text{ mm} \rightarrow \frac{1}{2}(13) = 6.5 \text{ mm}$

7. $16.36 \text{ m} \rightarrow \frac{1}{2}(16.36) = 8.18 \text{ m}$

4. $9 \text{ mi} \rightarrow \frac{1}{2}(9) = 4.5 \text{ mi}$

8. $4.63 \text{ cm} \rightarrow \frac{1}{2}(4.63) = 2.315 \text{ cm}$

The length of the side opposite the 30° angle in a 30° — 60° — 90° triangle is given. Find the length of the hypotenuse in each triangle.

9. $7 \text{ m} \rightarrow 2(7) = 14 \text{ m}$

13. $6\frac{3}{8} \text{ in.} \rightarrow 2(6\frac{3}{8}) = 12\frac{3}{4} \text{ in.}$

10. $6.2 \text{ cm} \rightarrow 2(6.2) = 12.4 \text{ cm}$

14. $13 \text{ m} \rightarrow 2(13) = 26 \text{ m}$

11. $4.35 \text{ mm} \rightarrow 2(4.35) = 8.70 \text{ mm}$

15. $3.86 \text{ cm} \rightarrow 2(3.86) = 7.72 \text{ cm}$

12. $4\frac{1}{2} \text{ mi} \rightarrow 2(4\frac{1}{2}) = 9 \text{ mi}$

16. $7\frac{3}{4} \text{ in} \rightarrow 2(7\frac{3}{4}) = 15\frac{1}{2} \text{ in.}$

The length of the side opposite the 60° angle in 30° — 60° — 90° triangle is given. Find the length of the other two sides in each triangle.

17. $4\sqrt{3} \text{ ft}$

$$x = z\sqrt{3}$$

$$4\sqrt{3} = z\sqrt{3}$$

$$4 = z$$

Since $y = 2z$, then $y = 2(4)$, or 8.

Thus, the side opposite 30° is 4 ft and the hypotenuse is 8 ft.

18. $2\sqrt{3}$ cm

$$x = z\sqrt{3}$$

$$2\sqrt{3} = z\sqrt{3}$$

$$2 = z$$

Since $y = 2z$, then $y = 2(2)$, or 4.

Thus, the side opposite 30° is 2 cm and the hypotenuse is 4 cm.

19. $8\sqrt{3}$ m

$$x = z\sqrt{3}$$

$$8\sqrt{3} = z\sqrt{3}$$

$$8 = z$$

Since $y = 2z$, then $y = 2(8)$, or 16.

Thus, the side opposite 30° is 8 m and the hypotenuse is 16 m.

20. $\sqrt{3}$ mi

$$x = z\sqrt{3}$$

$$\sqrt{3} = z\sqrt{3}$$

$$1 = z$$

Since $y = 2z$, then $y = 2(1)$, or 2.

Thus, the side opposite 30° is 1 mi and the hypotenuse is 2 mi.

21. $7\sqrt{3}$ yd

$$x = z\sqrt{3}$$

$$7\sqrt{3} = z\sqrt{3}$$

$$7 = z$$

Since $y = 2z$, then $y = 2(7)$, or 14.

Thus, the side opposite 30° is 7 yd and the hypotenuse is 14 yd.

22. $9\sqrt{3}$ mm

$$x = z\sqrt{3}$$

$$9\sqrt{3} = z\sqrt{3}$$

$$9 = z$$

Since $y = 2z$, then $y = 2(9)$, or 18.

Thus, the side opposite 30° is 9 mm and the hypotenuse is 18 mm.

Find the length of the third side in each triangle. Irrational answers are to be given in simplest form and then use a calculator to find answers to the nearest thousandths.

23.

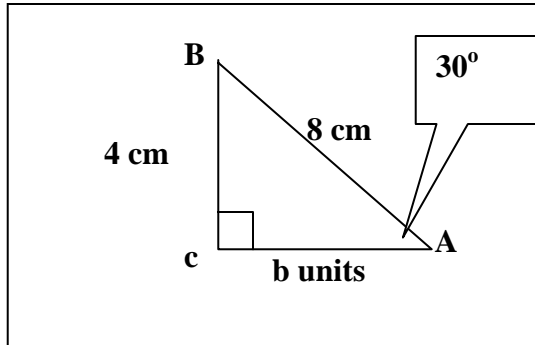

$$4\sqrt{3} \text{ cm} \rightarrow 6.928 \text{ cm}$$

24.

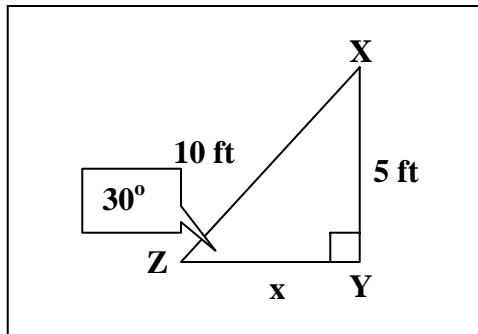

$$5\sqrt{3} \text{ ft} \rightarrow 8.660 \text{ ft}$$

25.

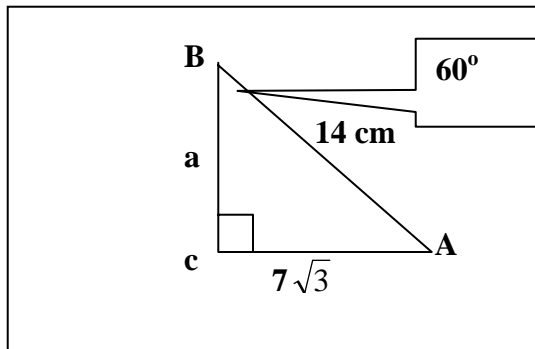

$$a\sqrt{3} = 7\sqrt{3}$$

$$a = 7 \text{ cm}$$

26.

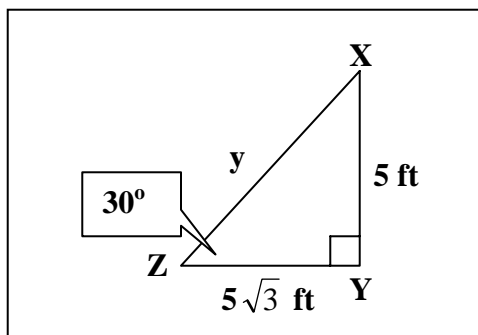

$$2(5) \rightarrow 10 \text{ ft}$$

27.

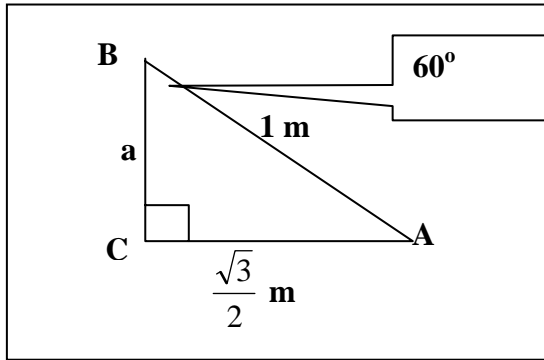

$$\frac{1}{2}(1) \rightarrow \frac{1}{2} \text{ m}$$

28.

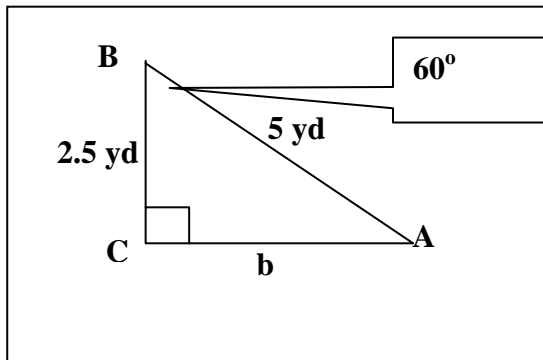

$$2.5\sqrt{3} \rightarrow 4.330 \text{ yd}$$

Find the lengths of the missing sides of each 30° — 60° — 90° triangle described below. Irrational answers are to be given in simplest form and then use a calculator to find answers to the nearest thousandths.

Question	Hypotenuse	Side Opposite 30° Angle	Side Opposite 60° Angle
29	6 m	$\frac{1}{2}(6) \rightarrow 3 \text{ m}$	$3\sqrt{3} \rightarrow 5.196 \text{ m}$
30	4.75 mm	$\frac{1}{2}(4.75) \rightarrow 2.375 \text{ mm}$	$2.375\sqrt{3} \rightarrow 4.114 \text{ mm}$
31	$3\frac{1}{2} \text{ in.}$	$\frac{1}{2}(3\frac{1}{2}) \rightarrow 1\frac{3}{4} \text{ in.}$	$1\frac{3}{4}(\sqrt{3}) \rightarrow 3.031 \text{ in.}$
32	$2(8) \rightarrow 16 \text{ cm}$	8 cm	$8\sqrt{3} \rightarrow 13.856 \text{ cm}$
33	$2(6.5) \rightarrow 13 \text{ m}$	6.5 m	$6.5\sqrt{3} \rightarrow 11.258$
34	$2(3\frac{1}{4}) \rightarrow 6\frac{1}{2} \text{ in.}$	$3\frac{1}{4} \text{ in.}$	$3\frac{1}{4}(\sqrt{3}) \rightarrow 5.629 \text{ in.}$
35	$2(2) \rightarrow 4 \text{ m}$	$\frac{\sqrt{12}}{\sqrt{3}} \rightarrow 2 \text{ m}$	$\sqrt{12}$
36	$2(3.5) \rightarrow 7 \text{ cm}$	$\frac{3.5\sqrt{3}}{\sqrt{3}} \rightarrow 3.5 \text{ cm}$	$3.5\sqrt{3}$

Student Name: _____

Date: _____

30-60-90 Right Triangles and Algebra Checklist

1. On questions 1 through 8, did the student find the length of the side opposite the 30° angle in the triangle?
 - a. All eight (40 points)
 - b. Seven of the eight (35 points)
 - c. Six of the eight (30 points)
 - d. Five of the eight (25 points)
 - e. Four of the eight (20 points)
 - f. Three of the eight (15 points)
 - g. Two of the eight (10 points)
 - h. One of the eight (5 points)

2. On questions 9 through 16, did the student find the length of the hypotenuse in each triangle?
 - a. All eight (40 points)
 - b. Seven of the eight (35 points)
 - c. Six of the eight (30 points)
 - d. Five of the eight (25 points)
 - e. Four of the eight (20 points)
 - f. Three of the eight (15 points)
 - g. Two of the eight (10 points)
 - h. One of the eight (5 points)

3. On question 17, did the student find the two missing sides correctly?
 - a. Both (10 points)
 - b. One of the two (5 points)

4. On question 18, did the student find the two missing sides correctly?
 - a. Both (10 points)
 - b. One of the two (5 points)

5. On question 19, did the student find the two missing sides correctly?
 - a. Both (10 points)
 - b. One of the two (5 points)

6. On question 20, did the student find the two missing sides correctly?
 - a. Both (10 points)
 - b. One of the two (5 points)

7. On question 21, did the student find the two missing sides correctly?
 - a. Both (10 points)
 - b. One of the two (5 points)

8. On question 22, did the student find the two missing sides correctly?
 - a. Both (10 points)
 - b. One of the two (5 points)

9. On question 23, did the student find the length of the third side of the triangle in simplest form and round the result to the nearest thousandths place?
 - a. Yes (10 points)
 - b. Yes, but did not round correctly (5 points)

10. On question 24, did the student find the length of the third side of the triangle in simplest form and round the result to the nearest thousandths place?
 - a. Yes (10 points)
 - b. Yes, but did not round correctly (5 points)

11. On questions 25 through 27, did the student find the length of the third side of the triangle in simplest form?
 - a. Yes (15 points)
 - b. Two of the three (10 points)
 - c. One of the three (5 points)

12. On question 28, did the student find the length of the third side of the triangle in simplest form and round the result to the nearest thousandths place?
 - a. Yes (10 points)
 - b. Yes, but did not round correctly (5 points)

13. On question 29, did the student find the two missing sides correctly leaving results in simplest form, and rounding the answer to the nearest thousandths?
 - a. Yes (15 points)
 - b. Both correct but one of the answers not rounded correctly (10 points)
 - c. One answer correct or both answers not rounded correctly (5 points)

14. On question 30, did the student find the two missing sides correctly leaving results in simplest form, and rounding the answer to the nearest thousandths?
 - a. Yes (15 points)
 - b. Both correct but one of the answers not rounded correctly (10 points)
 - c. One answer correct or both answers not rounded correctly (5 points)

15. On question 31, did the student find the two missing sides correctly leaving results in simplest form, and rounding the answer to the nearest thousandths?
 - a. Yes (15 points)
 - b. Both correct but one of the answers not rounded correctly (10 points)
 - c. One answer correct or both answers not rounded correctly (5 points)

16. On question 32, did the student find the two missing sides correctly leaving results in simplest form, and rounding the answer to the nearest thousandths?
- a. Yes (15 points)
 - b. Both correct but one of the answers not rounded correctly (10 points)
 - c. One answer correct or both answers not rounded correctly (5 points)
17. On question 33, did the student find the two missing sides correctly leaving results in simplest form, and rounding the answer to the nearest thousandths?
- a. Yes (15 points)
 - b. Both correct but one of the answers not rounded correctly (10 points)
 - c. One answer correct or both answers not rounded correctly (5 points)
18. On question 34, did the student find the two missing sides correctly leaving results in simplest form, and rounding the answer to the nearest thousandths?
- a. Yes (15 points)
 - b. Both correct but one of the answers not rounded correctly (10 points)
 - c. One answer correct or both answers not rounded correctly (5 points)
19. On questions 34 and 35, did the student find the two missing sides correctly leaving results in simplest form?
- a. Yes (15 points)
 - b. Both correct but not in simplest form (10 points)
 - c. One correct and one or both not in simplest form (5 points)

Total Number of Points _____

- A 261 points and above
- B 232 points and above
- C 203 points and above
- D 174 points and above
- F 173 points and below

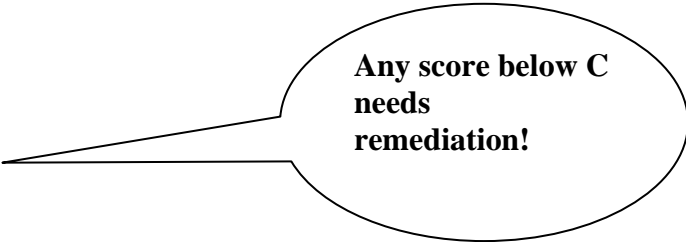

**Any score below C
needs
remediation!**